

Original 3 channel setup

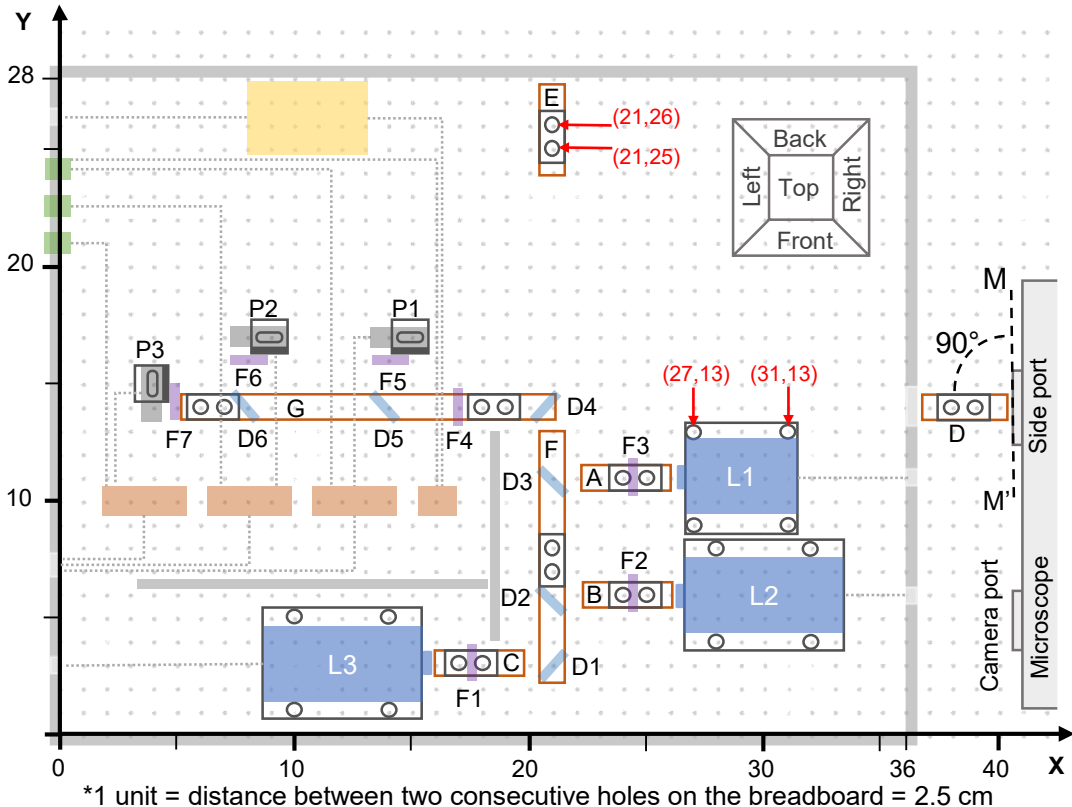

b

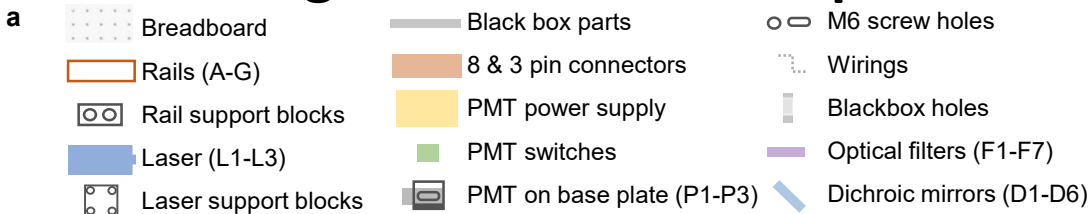
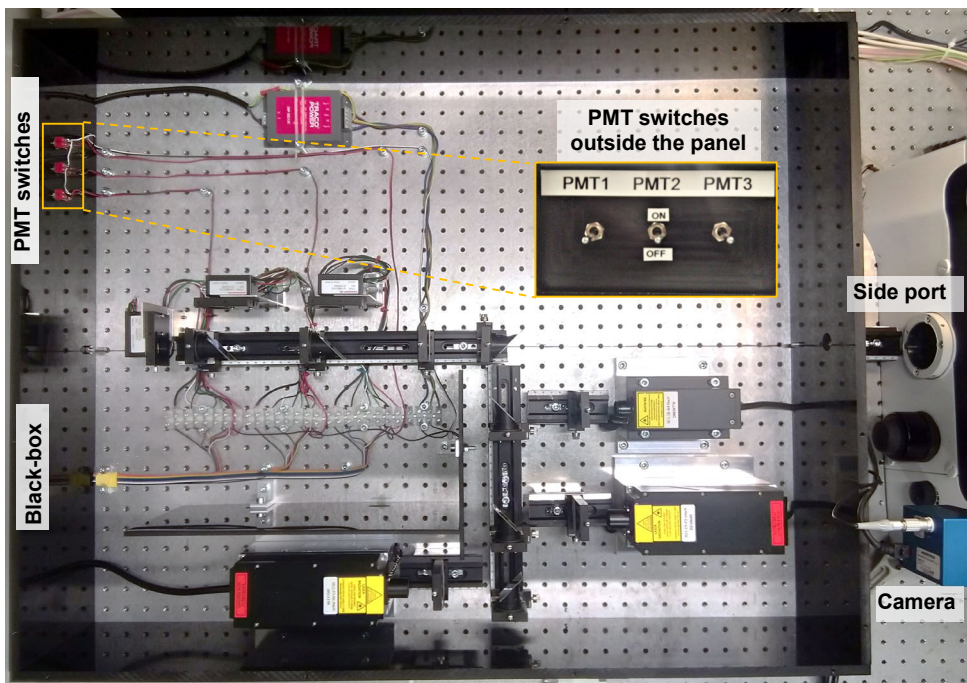

BIOENG-421 single channel setup

Groups A

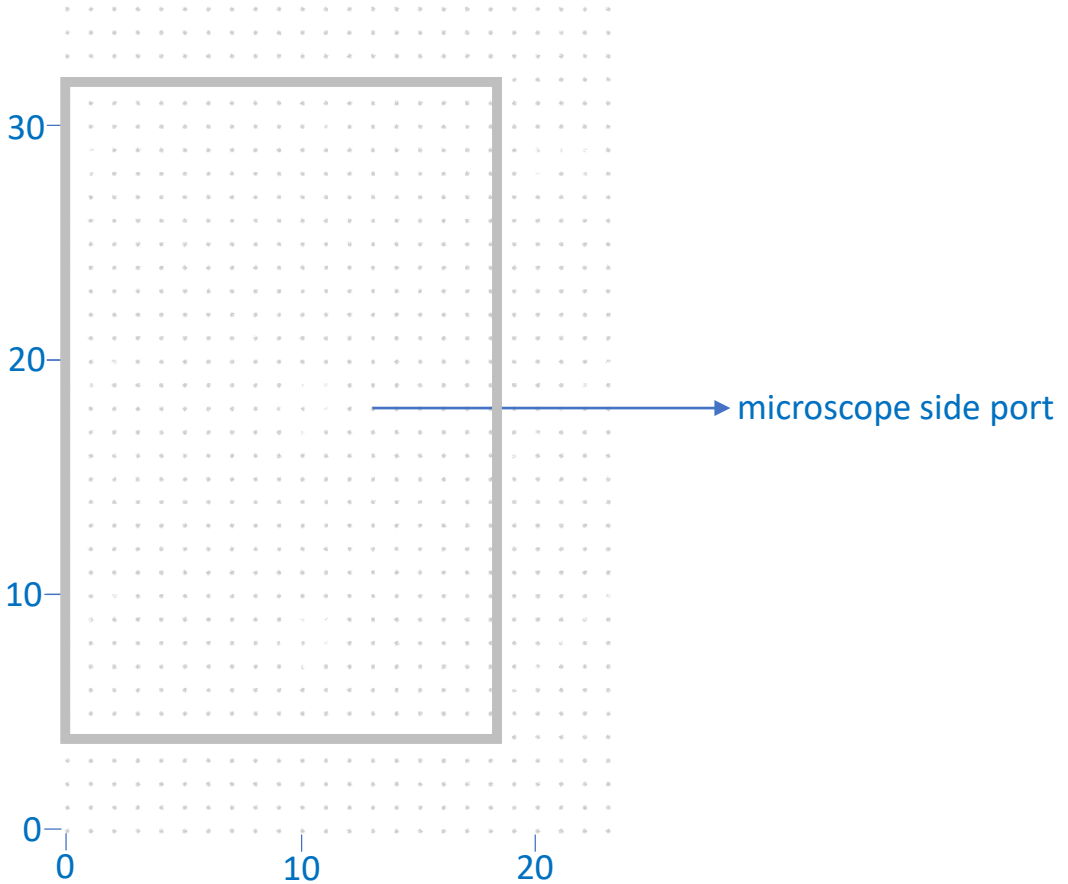

Group A: Atomic Force Microscopy (practical session 8.15am – 10am, 473nm laser)

BIOENG-421 single channel setup

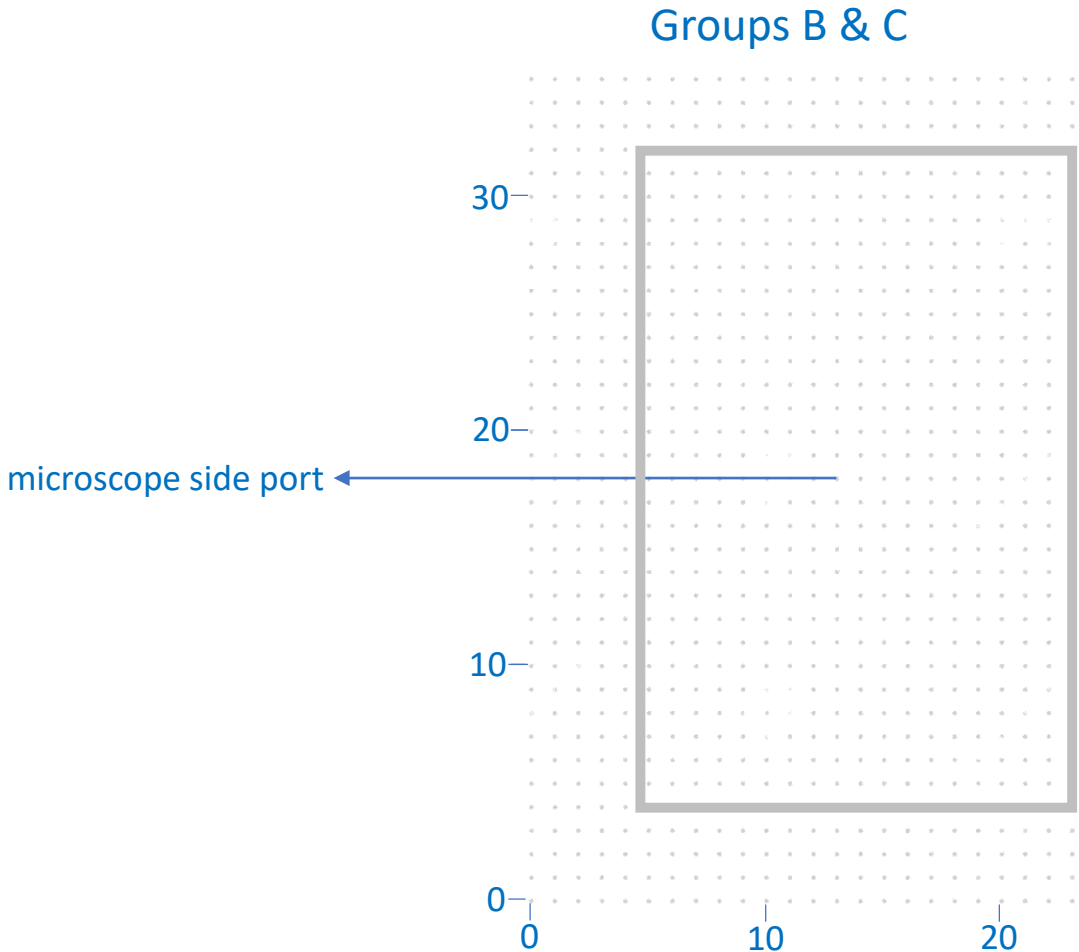

Group B: Surface Plasmon Resonance (practical session 10.15am – noon, 473nm laser)

Group C: Mass Spectrometry (practical session 8.15am – 10am, 561nm laser)